

Capacity Data: ZG Models 50, 65, 80, 100

MODEL	SPEED RPM	Theoretical Capacity CFM	2PSI		3PSI		4PSI		5PSI		6PSI		7PSI		8PSI		9PSI		10PSI		12PSI		14PSI		15PSI		
			CFM	BHP	CFM	BHP	CFM	BHP	CFM	BHP	CFM	BHP	CFM	BHP	CFM	BHP	CFM	BHP	CFM	BHP	CFM	BHP	CFM	BHP	CFM	BHP	CFM
ZG 50	1450	60	36	1.1	27	1.4	20	1.5	16	1.8	13	2.1	9	2.4													
	2000	82	58	1.6	49	1.9	44	2.2	40	2.6	35	3.0	31	3.3	33	3.7	20	4.1	22	4.4							
	2500	103	79	1.9	70	2.4	65	2.7	61	3.2	56	3.7	52	4.1	54	4.6	41	5.0	43	5.4							
	3000	124	99	2.1	90	2.6	86	3.2	82	3.8	77	4.4	73	4.9	75	5.4	62	5.9	63	6.4	57	7.6					
	3500	144	120	2.4	111	3.1	106	3.7	102	4.4	97	4.9	93	5.6	95	6.2	82	6.9	84	7.5	78	8.8	75	10.1	72	10.7	
	4000	165	141	2.7	132	3.5	127	4.2	123	5.0	118	5.6	114	6.4	116	7.1	103	7.9	104	8.5	99	10.0	96	11.4	93	12.1	
	4500	185	161	3.1	152	3.9	148	4.8	144	5.5	138	6.4	135	7.2	137	8.0	123	8.8	124	9.5	119	11.2	117	12.8	114	13.6	
5000	206	182	3.4	172	4.3	168	5.3	164	6.1	159	7.1	155	8.0	157	8.8	144	9.7	146	10.6	139	12.3	136	14.2	134	15.1		

MODEL	SPEED RPM	Theoretical Capacity CFM	2PSI		3PSI		4PSI		5PSI		6PSI		7PSI		8PSI		9PSI		10PSI		12PSI		14PSI		15PSI		
			CFM	BHP	CFM	BHP	CFM	BHP	CFM	BHP	CFM	BHP	CFM	BHP	CFM	BHP	CFM	BHP	CFM	BHP	CFM	BHP	CFM	BHP	CFM	BHP	CFM
ZG 65	2000	138	104	2.3	98	2.9	77	3.5	70	4.1	61	4.7	55	5.3	50	5.9	44	6.5	41	7.1							
	2500	173	140	2.9	134	3.6	112	4.4	105	5.1	96	5.9	90	6.6	85	7.4	79	8.1	76	8.9	69	10.4					
	3000	208	175	3.4	169	4.3	146	5.3	139	6.2	130	7.0	124	8.0	119	8.9	114	9.8	111	10.7	103	12.6	100	14.3	97	15.2	
	3500	243	211	4.1	205	5.1	181	6.2	174	7.2	165	8.2	159	9.3	154	10.3	149	11.4	145	12.5	138	14.6	135	16.7	131	17.7	
	4000	277	246	4.6	241	5.8	216	7.1	208	8.2	200	9.4	193	10.6	189	11.8	183	13.1	180	14.2	172	16.6	170	19.0	166	20.3	
	4500	312	282	5.2	276	6.5	250	7.8	243	9.3	234	10.6	228	11.9	223	13.4	218	14.7	214	16.0	207	18.7	204	21.4	200	22.8	
5000	347	317	5.7	312	7.2	285	8.7	278	10.2	269	11.7	263	13.3	258	14.8	253	16.3	249	17.7	242	20.8	239	23.8	235	25.3		

MODEL	SPEED RPM	Theoretical Capacity CFM	2PSI		3PSI		4PSI		5PSI		6PSI		7PSI		8PSI		9PSI		10PSI		12PSI		14PSI		15PSI		
			CFM	BHP	CFM	BHP	CFM	BHP	CFM	BHP	CFM	BHP	CFM	BHP	CFM	BHP	CFM	BHP	CFM	BHP	CFM	BHP	CFM	BHP	CFM	BHP	CFM
ZG 80	2000	257	204	3.8	193	4.9	184	6.0	176	7.1	170	8.2	165	9.3	167	10.4	154	11.5	152	12.6							
	2300	296	243	4.3	232	5.6	224	6.9	216	8.2	210	9.4	205	10.7	207	12.1	194	13.4	191	14.6	184	17.2					
	2500	321	270	4.7	259	6.1	251	7.5	243	8.8	237	10.3	232	11.7	234	13.1	221	14.5	218	15.8	210	18.7	207	21.6	203	23.0	
	2800	357	310	5.3	298	6.8	290	8.4	282	9.9	277	11.6	272	13.1	274	14.6	261	16.2	258	17.7	251	20.9	246	23.9	242	25.5	
	3000	385	335	5.8	325	7.5	317	9.1	309	10.8	303	12.5	298	14.2	300	15.9	288	17.6	285	19.2	277	22.6	273	25.9	269	27.6	
	3300	424	373	6.4	365	8.2	355	10.1	347	11.9	343	13.8	338	15.6	340	17.5	328	19.4	325	21.1	317	24.8	313	28.6	309	30.4	
	3500	448	398	6.8	390	8.8	380	10.6	372	12.6	369	14.6	365	16.6	367	18.6	354	20.5	351	22.3	344	26.4	339	30.3	336	32.2	
	3800	487	441	7.3	429	9.5	422	11.7	414	13.7	408	15.9	404	18.0	406	20.1	392	22.2	392	24.3	382	28.6	380	32.8	376	34.9	
4000	512	466	7.6	458	9.9	450	12.2	443	14.4	436	16.6	428	18.8	430	21.1	422	23.3	416	25.5	410	30.0	407	34.5	403	36.7		

MODEL	SPEED RPM	Theoretical Capacity CFM	2PSI		3PSI		4PSI		5PSI		6PSI		7PSI		8PSI		9PSI		10PSI		12PSI		14PSI		15PSI		
			CFM	BHP	CFM	BHP	CFM	BHP	CFM	BHP	CFM	BHP	CFM	BHP	CFM	BHP	CFM	BHP	CFM	BHP	CFM	BHP	CFM	BHP	CFM	BHP	CFM
ZG 100	2000	385	310	5.3	296	7.0	283	8.5	271	10.3	262	12.0	254	13.6	257	15.4	239	17.0	234	18.7	222	22.0					
	2300	441	370	6.2	355	8.1	342	10.0	330	12.0	322	13.8	314	15.8	317	17.8	299	19.7	294	21.5	283	25.5					
	2500	480	409	6.7	393	8.8	381	11.0	369	13.1	361	15.1	354	17.2	357	19.3	340	21.4	334	23.5	323	27.7	316	31.9	310	34.0	
	2800	540	469	7.7	454	10.0	441	12.4	429	14.8	421	17.1	414	19.5	417	21.8	399	24.2	395	26.4	384	31.2	376	36.0	370	38.3	
	3000	579	508	8.3	496	10.9	483	13.3	472	15.8	463	18.4	453	20.9	456	23.5	441	26.0	434	28.4	423	33.5	414	38.6	409	41.1	
	3300	636	568	9.1	552	11.8	543	14.6	532	17.4	523	20.1	517	22.9	520	25.6	501	28.4	494	31.1	483	36.8	478	42.3	472	45.1	
	3500	674	608	9.5	595	12.4	582	15.5	571	18.4	562	21.3	555	24.2	558	27.2	540	30.1	536	32.9	522	39.0	517	44.8	511	47.8	
	3800	731	668	10.3	651	13.5	642	16.6	631	19.8	622	23.0	615	26.2	618	29.5	600	32.6	596	35.7	586	42.2	577	48.5	571	51.7	
4000	770	707	10.7	694	14.1	681	17.5	670	20.8	661	24.2	654	27.6	657	31.0	643	34.3	635	37.4	625	44.4	616	51.0	610	54.4		

Notes: Pressure ratings based on inlet air at standard pressure of 14.7 psia, standard temperature of 68°F, and specific gravity of 1.0

Capacity Data: ZG Models 125, 150, 200, 250

MODEL	SPEED	Theoretical Capacity CFM	2PSI		3PSI		4PSI		5PSI		6PSI		7PSI		8PSI		9PSI		10PSI		12PSI		14PSI		15PSI	
	RPM		CFM	BHP	CFM	BHP	CFM	BHP	CFM	BHP	CFM	BHP	CFM	BHP	CFM	BHP	CFM	BHP	CFM	BHP	CFM	BHP	CFM	BHP	CFM	BHP
ZG 125	1450	558	457	7.3	438	9.8	421	12.4	405	15.0	395	16.8	386	19.2	380	22.5	370	24.9	364	27.3	347	32.6	342	37.5	334	39.9
	1750	671	575	8.4	555	11.3	541	14.4	526	17.5	515	20.4	506	23.3	497	26.4	486	29.3	480	32.3	468	38.5	461	44.3	453	47.2
	2000	770	674	9.5	654	12.9	640	16.4	625	19.8	614	23.4	605	26.8	596	30.2	585	33.5	579	37.0	567	44.0	560	50.8	552	54.1
	2300	883	790	11.0	770	14.8	756	18.8	741	22.7	730	26.7	721	30.6	712	34.6	701	38.5	699	42.4	684	50.5	680	58.2	673	62.0
	2600	999	908	12.4	887	16.8	873	21.3	858	25.7	847	30.3	838	34.7	831	39.2	821	43.5	816	48.0	804	57.1	796	65.8	789	70.2
	2800	1077	984	13.4	968	18.1	950	22.9	935	27.8	928	32.6	919	37.3	909	42.2	899	46.9	897	51.7	881	61.5	874	71.0	867	75.7
	3000	1155	1062	14.3	1046	19.3	1032	24.6	1017	29.8	1006	35.0	997	40.0	990	45.3	980	50.3	975	55.5	963	66.0	955	76.1	948	81.2

MODEL	SPEED	Theoretical Capacity CFM	2PSI		3PSI		4PSI		5PSI		6PSI		7PSI		8PSI		9PSI		10PSI		12PSI		14PSI		15PSI	
	RPM		CFM	BHP	CFM	BHP	CFM	BHP	CFM	BHP	CFM	BHP	CFM	BHP	CFM	BHP	CFM	BHP	CFM	BHP	CFM	BHP	CFM	BHP	CFM	BHP
ZG 150	1450	893	747	10.9	719	14.8	695	18.8	672	22.8	658	26.8	645	30.7	633	34.7	618	38.6	610	42.7	592	50.7	585	58.5	575	62.4
	1750	1077	935	12.9	906	17.6	885	22.5	863	27.2	849	32.1	835	36.8	827	41.7	812	46.4	804	51.2	783	60.9	775	70.3	765	75.0
	2000	1232	1094	14.7	1066	20.0	1044	25.6	1022	31.1	1007	36.7	998	42.1	986	47.6	971	53.0	963	58.5	945	69.6	938	80.3	928	85.7
	2300	1416	1282	16.7	1257	22.8	1238	29.2	1217	35.6	1202	42.0	1188	48.2	1180	54.5	1165	60.6	1157	67.0	1141	79.6	1132	92.1	1122	98.3
	2600	1600	1474	18.7	1447	25.7	1428	32.9	1408	40.0	1392	47.2	1383	54.1	1370	61.4	1356	68.4	1348	75.4	1331	89.8	1323	103.5	1313	111
	2800	1723	1602	20.1	1574	27.6	1555	35.3	1536	43.0	1520	50.7	1510	58.3	1501	66.1	1488	73.6	1479	81.2	1462	97.1	1453	111.3	1444	119
	3000	1847	1725	21.4	1702	29.5	1682	37.7	1663	46.0	1651	54.4	1637	62.5	1628	70.8	1615	78.8	1606	87.0	1589	104	1580	120.2	1571	128

MODEL	SPEED	Theoretical Capacity CFM	2PSI		3PSI		4PSI		5PSI		6PSI		7PSI		8PSI		9PSI		10PSI		12PSI		14PSI		15PSI	
	RPM		CFM	BHP	CFM	BHP	CFM	BHP	CFM	BHP	CFM	BHP	CFM	BHP	CFM	BHP	CFM	BHP	CFM	BHP	CFM	BHP	CFM	BHP	CFM	BHP
ZG 200	970	1554	1327	18.2	1285	25.0	1245	31.9	1210	39.0	1187	46.0	1165	52.8	1143	59.9	1182	66.7	1104	73.7	1071	87.7	1056	101.5	1038	108
	1250	2002	1785	23.4	1741	32.1	1704	41.2	1669	50.2	1643	59.3	1624	68.1	1606	77.0	1582	85.7	1567	94.7	1535	113	1515	130.1	1498	139
	1450	2323	2109	26.8	2066	36.9	2032	47.4	1998	57.9	1972	68.4	1952	78.5	1934	89.0	1910	99.1	1895	110	1863	130	1844	150.8	1827	161
	1600	2564	2354	29.4	2309	40.5	2276	52.1	2242	63.7	2220	75.3	2196	86.4	2177	98.0	2154	109	2142	121	2110	144	2091	166.5	2074	178
	1750	2804	2599	32.0	2553	44.2	2520	56.9	2487	69.6	2463	82.2	2443	94.4	2424	107	2401	119	2386	132	2357	156	2338	182.3	2321	195
	1900	3044	2842	34.7	2800	48.0	2767	61.7	2734	75.5	2710	89.3	2690	103	2671	116	2648	130	2633	143	2605	171	2585	198.1	2569	212
	2050	3284	3082	37.3	3045	51.6	3010	66.4	2977	81.3	2954	96.2	2934	111	2918	125	2896	140	2880	155	2848	185	2832	212.8	2816	227

MODEL	SPEED	Theoretical Capacity CFM	2PSI		3PSI		4PSI		5PSI		6PSI		7PSI		8PSI		9PSI		10PSI		12PSI		14PSI		15PSI	
	RPM		CFM	BHP	CFM	BHP	CFM	BHP	CFM	BHP	CFM	BHP	CFM	BHP	CFM	BHP	CFM	BHP	CFM	BHP	CFM	BHP	CFM	BHP	CFM	BHP
ZG 250	970	1981	1716	22.5	1669	31.2	1628	40.0	1587	49.0	1560	57.8	1539	66.5	1519	75.4	1491	84.1	1481	92.8						
	1250	2553	2298	28.9	2248	40.0	2211	51.5	2171	63.1	2146	74.6	2125	85.8	2104	97.2	2077	108	2068	120						
	1450	2959	2712	33.1	2665	46.1	2628	59.4	2586	72.9	2563	86.2	2542	99.2	2525	113	2499	126	2485	139						
	1600	3266	3023	36.6	2976	50.8	2941	65.6	2903	80.4	2876	95.4	2856	110	2839	124	2813	139	2799	154						
	1750	3566	3336	39.9	3291	55.5	3252	71.7	3215	88.0	3189	104	3170	120	3152	137	3127	152	3113	168						
	1900	3884	3632	43.4	3601	60.4	3566	78.1	3529	95.9	3503	114	3485	131	3466	148	3441	165	3428	183						
	2050	4202	3950	47.0	3911	65.3	3877	84.5	3839	104	3818	123	3795	142	3782	161	3756	179	3742	198						

Notes: Pressure ratings based on inlet air at standard pressure of 14.7 psia, standard temperature of 68°F and specific gravity of 1.0

Capacity Data: ZG Models 50V, 65V, 80V, 100V

MODEL	SPEED	Theoretical Capacity CFM	3"Hg		6"Hg		9"Hg		12"Hg		15"Hg	
	RPM		CFM	BHP	CFM	BHP	CFM	BHP	CFM	BHP	CFM	BHP
ZG 50V	2000	82	60	1.4	42	1.9	30	2.3				
	2500	103	80	1.6	63	2.3	50	2.9	40	3.6		
	3000	124	101	1.9	84	2.6	71	3.4	61	4.3		
	3500	144	122	2.2	104	3.0	92	4.0	82	5.0		
	4000	165	143	2.5	125	3.4	113	4.5	102	5.6	86	6.6
	4500	185	163	2.7	145	3.8	133	5.1	123	6.2	107	7.5
	5000	206	184	3.0	166	4.3	154	5.6	143	6.9	127	8.3
ZG 65V	2500	173	137	2.5	113	3.6	95	4.7	79	5.8		
	3000	208	172	3.0	147	4.3	129	5.6	113	7.0		
	3500	243	206	3.4	182	5.1	164	6.6	148	8.1		
	4000	277	241	4.0	217	5.8	199	7.6	183	9.2	170	11.0
	4500	312	275	4.4	251	6.4	233	8.4	217	10.5	204	12.4
	5000	347	310	4.9	286	7.1	268	9.4	252	11.6	239	13.8
ZG 80V	2000	257	210	3.1	187	4.8	167	6.5	147	8.1		
	2300	296	249	3.7	227	5.5	207	7.4	188	9.4		
	2500	321	275	4.0	254	6.0	234	8.1	215	10.1	193	12.2
	2800	360	315	4.5	293	6.7	274	9.1	254	11.3	233	13.7
	3000	385	341	4.9	320	7.4	301	9.8	281	12.3	260	14.8
	3300	424	381	5.5	360	8.1	341	10.9	322	13.5	300	16.3
	3500	448	406	5.7	385	8.7	367	11.4	348	14.4	327	17.3
	3800	487	445	6.3	427	9.3	409	12.5	387	15.6	369	18.8
	4000	516	473	6.6	452	9.8	434	13.1	416	16.4	393	19.6
ZG 100V	2000	385	319	4.4	287	6.9	259	9.2	229	11.7		
	2300	445	378	5.1	347	8.0	319	10.8	290	13.7		
	2500	480	417	5.6	388	8.7	359	11.9	331	14.9	299	18.0
	2800	540	477	6.4	448	9.9	419	13.4	390	16.8	361	20.3
	3000	579	515	7.0	487	10.7	458	14.3	433	18.1	399	21.8
	3300	636	575	7.5	547	11.7	518	15.7	493	19.9	463	23.9
	3500	674	614	7.9	586	12.2	561	16.7	532	21.0	502	25.3
	3800	731	674	8.6	646	13.3	621	17.9	592	22.7	562	27.4
	4000	770	713	9.0	685	13.9	659	18.9	634	23.8	604	28.8



Capacity Data: ZG Models 125V, 150V, 200V, 250V

MODEL	SPEED	Theoretical Capacity CFM	3"Hg		6"Hg		9"Hg		12"Hg		15"Hg	
	RPM		CFM	BHP	CFM	BHP	CFM	BHP	CFM	BHP	CFM	BHP
ZG 125V	1450	558	469	5.6	427	9.6	391	13.4	354	17.1		
	1750	674	586	6.7	547	11.2	511	15.6	471	20.1	430	24.4
	2000	770	685	7.7	642	12.7	606	17.8	570	22.8	529	28.0
	2300	883	801	8.8	762	14.6	726	20.4	690	26.1	649	32.0
	2600	999	918	9.9	879	16.5	843	23.1	810	29.6	769	36.3
	2800	1077	996	10.7	956	17.8	924	24.9	888	32.0	851	39.0
	3000	1155	1073	11.4	1034	19.0	1002	26.7	969	34.3	928	41.8
ZG 150V	1450	893	762	8.7	702	14.6	648	20.5	593	26.3		
	1750	1077	953	10.3	893	17.4	842	24.5	788	31.4	728	38.5
	2000	1232	1109	11.7	1051	19.7	1001	27.8	950	35.8	895	44.0
	2300	1416	1299	13.3	1242	22.5	1195	31.8	1144	41.1	1089	50.4
	2600	1600	1486	14.8	1433	25.3	1386	35.8	1339	46.2	1283	56.7
	2800	1723	1613	15.9	1560	27.2	1513	38.5	1470	49.7	1414	61.0
	3000	1847	1741	16.9	1687	29.0	1644	41.1	1597	53.2	1545	65.4
ZG 200V	970	1554	1352	14.3	1259	24.6	1173	34.7	1086	45.0		
	1250	2002	1808	18.6	1715	31.6	1632	44.8	1548	58.0	1452	71.2
	1450	2323	2132	21.2	2043	36.3	1961	51.6	1877	66.9	1785	82.2
	1600	2564	2376	23.1	2287	39.9	2208	56.7	2124	73.7	2032	90.5
	1750	2800	2620	25.2	2531	43.5	2451	62.0	2371	80.4	2283	98.8
	1900	3040	2863	27.2	2774	47.2	2699	67.2	2619	87.2	2530	107
	2050	3280	3107	29.2	3021	50.8	2946	72.4	2866	94.0	2777	116
ZG 250V	970	1977	1747	17.7	1637	30.7	1543	43.6	1449	56.6	1341	69.6
	1250	2549	2327	22.6	2220	39.4	2130	56.2	2035	73.0	1935	89.8
	1450	2959	2736	25.7	2636	45.3	2546	64.8	2455	84.3	2355	104
	1600	3266	3050	28.4	2951	50.0	2861	71.5	2773	93.1	2673	115
	1750	3570	3361	31.0	3261	54.6	3175	78.2	3088	102	2991	125
	1900	3877	3672	33.7	3565	59.4	3489	85.1	3402	111	3306	137
	2050	4184	3983	36.3	3886	64.3	3804	92.2	3720	120	3624	148

Notes: Vacuum ratings based on inlet air at standard temperature of 68° F, discharge of 30" Hg and specific gravity of 1.0



ZG Series Technical Data

ZG-50 Outline Drawing

Unit: inch Weight: 101lb

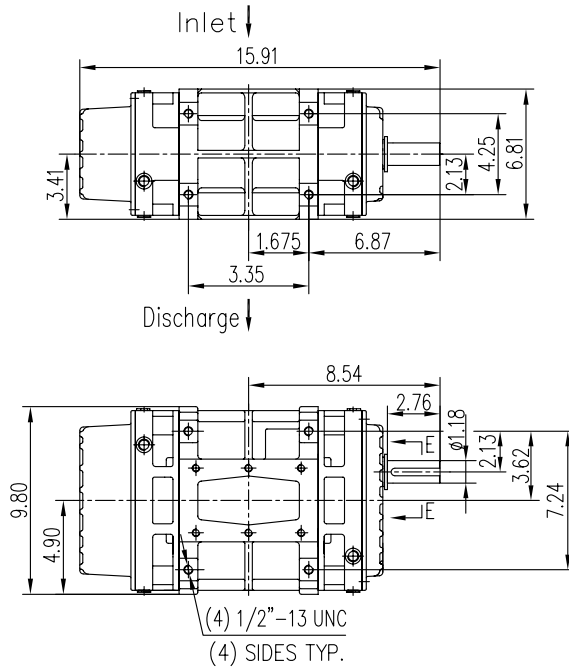

Inlet and Outlet Flange Size

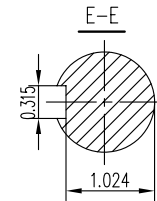
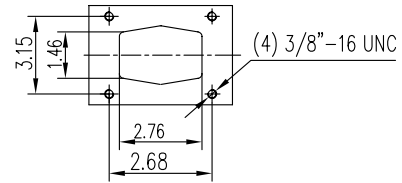

ZG-65 Outline Drawing

Unit: inch Weight: 123lb

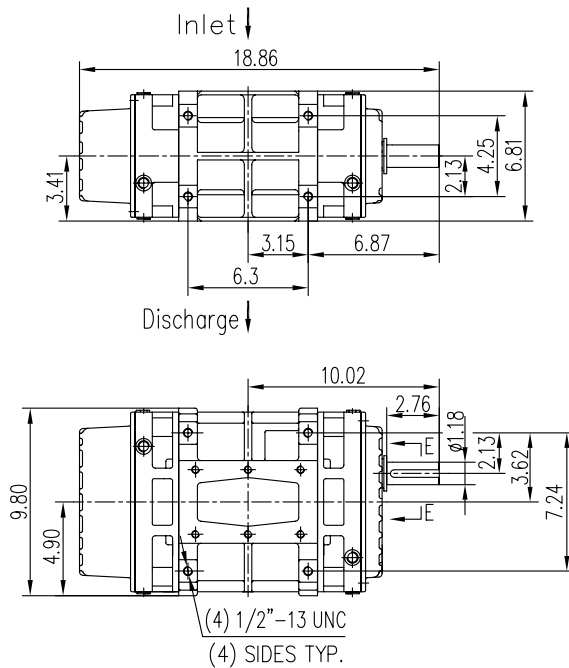

Inlet and Outlet Flange Size

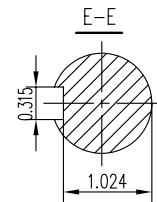
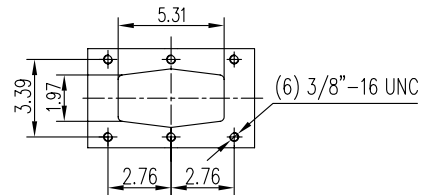

ZG Series Technical Data

ZG-100 Outline Drawing

Unit: inch Weight: 254lb

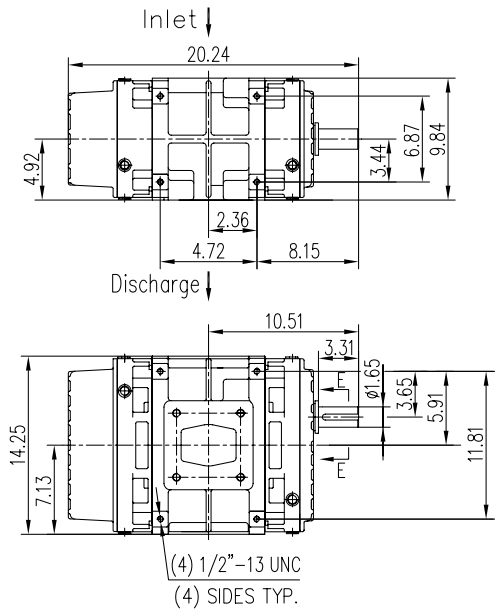

Inlet and Outlet Flange Size

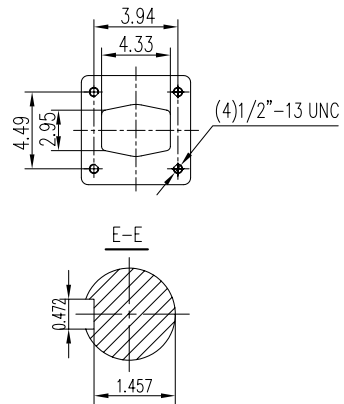

ZG-100 Outline Drawing

Unit: inch Weight: 298lb

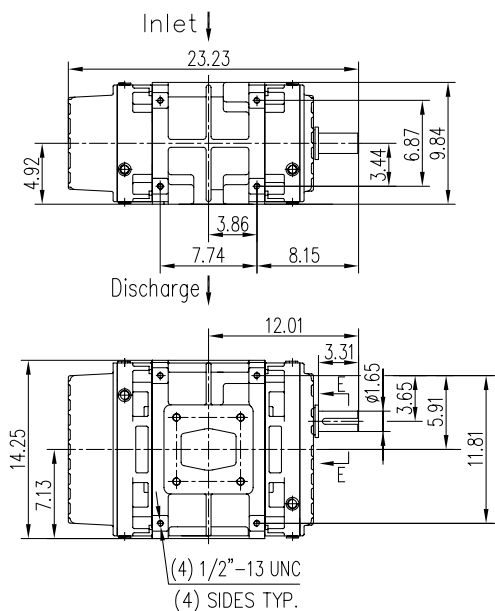

Inlet and Outlet Flange Size

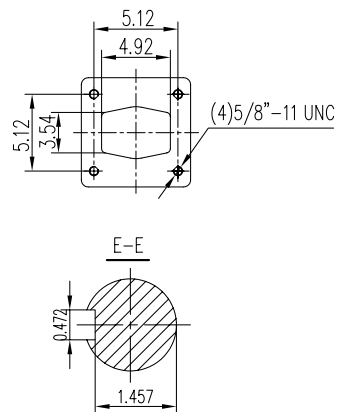

ZG Series Technical Data

ZG-125 Outline Drawing

Unit: inch Weight: 66lb

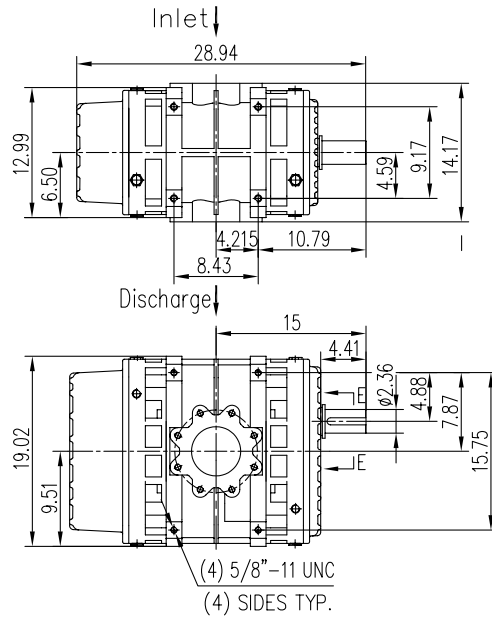

Inlet and Outlet Flange Size

ANSI 150lb

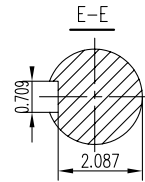
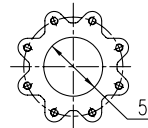

ZG-150 Outline Drawing

Unit: inch Weight: 796lb

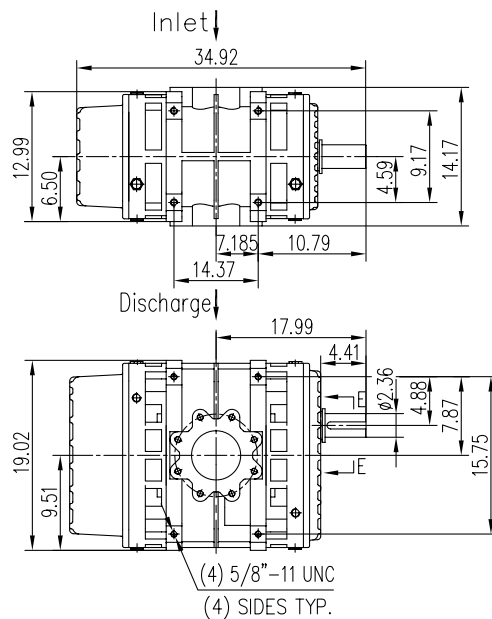

Inlet and Outlet Flange Size

ANSI 150lb

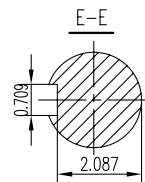
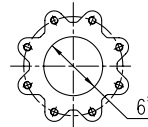

ZG Series Technical Data

ZG-200 Outline Drawing

Unit: inch Weight: 1620lb

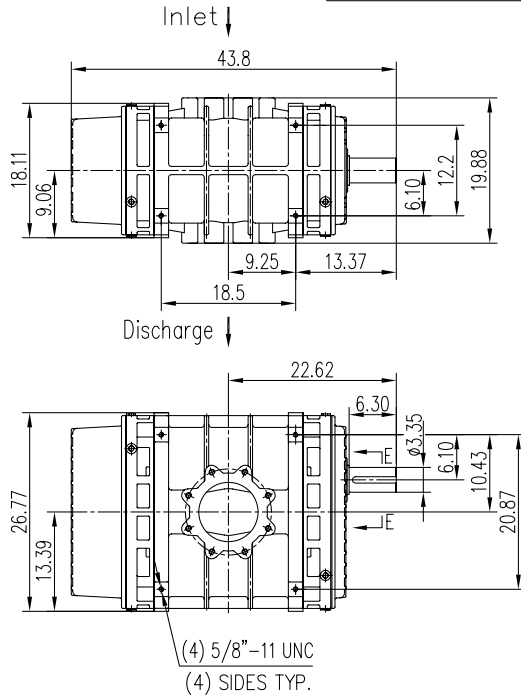

Inlet and Outlet Flange Size
ANSI 150lb

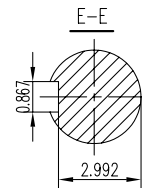
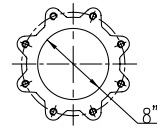

ZG-250 Outline Drawing

Unit: inch Weight: 1907lb

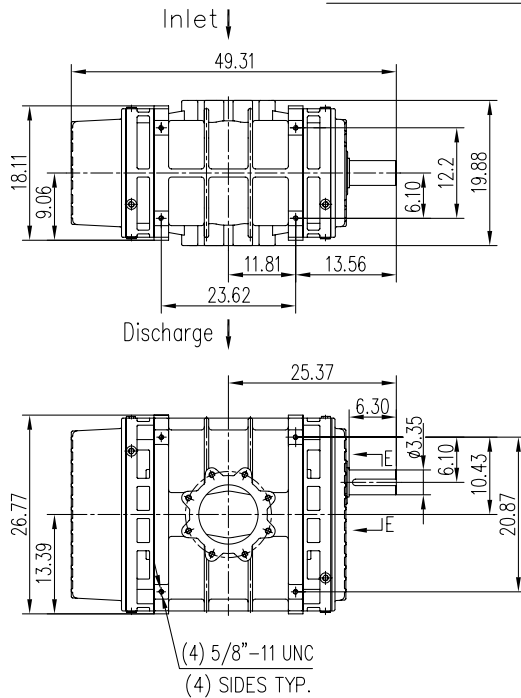

Inlet and Outlet Flange Size
ANSI 150lb

